





ADVANCED CONNECTION SYSTEMS FOR OFFSHORE TUBULARS

Providing Total Solutions Through Connector Technology

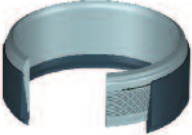

The logo for Oil States Industries (UK), Ltd. It features a stylized 'O' with a white wave-like shape inside, followed by the word 'Oil' in a bold, sans-serif font, and 'States' in a larger, bold, sans-serif font below it. A registered trademark symbol (®) is located to the right of 'Oil'.
Oil States
OIL STATES INDUSTRIES (UK), LTD.

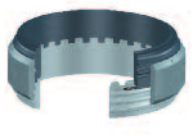
Worldwide Leaders In Connector Technology

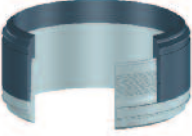
Connector Range	Key Features								Assembly	Page	
	Reversible	Reusable	Pleable	Metal Seals	Remote Release	Elastomer Seals	High Torque	Pre-Loaded			
SWIFT											
	✓	✓		✓		✓			✓	1 ¹ / ₂ Turn Rotation	2
LEOPARD											
	✓	✓	✓			✓			✓	<1 Turn Rotation	3
LYNX											
	✓	✓	✓		✓	✓	✓			Weight Set	4/5
PUMA											
	✓	✓	✓			✓			✓	4 Turn Rotation	6
MERLIN											
	✓	✓	✓	✓				✓	✓	Hydraulic Clamp	7/8/9

Swift

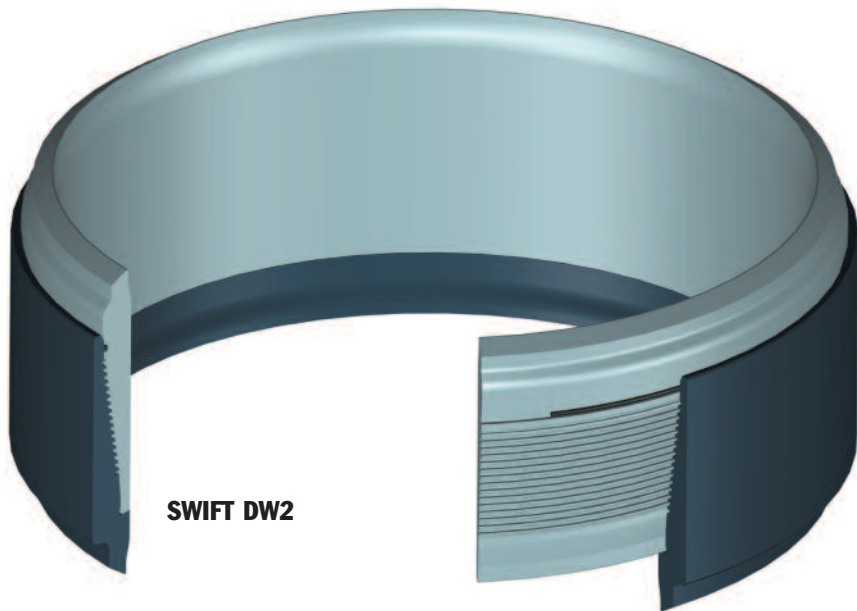

SWIFT DW2

Metal-seal connector for conductor and casing

- Pre-loaded for fatigue
- Primary metal seal, back-up elastomer
- Environmental seal
- Strength equivalent to casing
- Reversible and reusable
- Fast twin start, low-torque make-up using rig tongs

The Swift DW2 is a heavy-duty threaded connector for use on exploration and platform casing strings where high strength and pressure integrity are important. Compared to other connectors of similar performance, the Swift DW2 requires very low make-up torque and can be assembled using standard rig tongs.

The Swift DW2 combines a rugged, double-start thread form with a deep stabbing design to eliminate cross threading. The double-start thread reaches full pre-loaded make-up in 1 1/2 rotations. Maximum torque required is between 20,000 and 26,000 ft-lb for a 20" design. Full make-up is visually confirmed by inspecting external indicator faces (see drawing). Sealing is provided by an integral metal-to-metal seal, with an elastomer O-ring secondary seal.

Swift DW2 connectors can be reused multiple times.

Materials

Swift connectors are typically made from X60 material. Alternate material options are available on request.

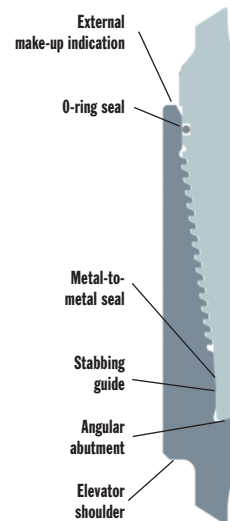

Type	Mat Yield		Pipe Nominal OD		Pipe Wall Thickness		Connector OD		Connector ID		Made-up Length		Tension Yield		Bending Yield		Compression Yield		Internal Yield Pressure		Make-up Torque	
	(ksi)	(in)	(mm)	(in)	(mm)	(in)	(mm)	(in)	(mm)	(in)	(mm)	(kips)	(MN)	(kips ft)	(MNm)	(kips)	(MN)	(psi)	(MPa)	(kips ft)	(kNm)	
DW2	60	18.625	473	0.435	11.0	20.50	521	17.76	451	10.01	254	1,491	6.6	552	0.7	940	4.2	2,500	17.2	18 to 21	24.4 to 28.5	
DW2	60	18.625	473	0.5	12.7	20.14	512	17.37	441	10.01	254	1,708	7.6	628	0.9	937	4.2	2,800	19.3	18 to 21	24.4 to 28.5	
DW2	60	20	508	0.438	11.1	21.50	546	18.75	476	10.01	254	1,615	7.2	644	0.9	1,000	4.4	2,300	15.9	20 to 26	27.1 to 35.3	
DW2	60	20	508	0.5	12.7	21.50	546	18.75	476	10.01	254	1,838	8.2	728	1.0	1,000	4.4	2,700	18.6	20 to 26	27.1 to 35.3	
DW2	60	20	508	0.625	15.9	21.50	546	18.75	476	10.01	254	2,130	9.5	834	1.1	1,000	4.4	3,300	22.8	20 to 26	27.1 to 35.3	
DW2	100	20	508	0.625	15.9	21.50	546	18.75	476	10.01	254	3,551	15.8	1,390	1.9	1,667	7.4	5,000	34.5	20 to 26	27.1 to 35.3	
DW2	100	20	508	1.0	25.4	21.25	540	18.00	457	10.88	276	4,334	19.3	1,634	2.2	2,746	12.2	5,000	34.5	20 to 26	27.1 to 35.3	
DW2	60	22	559	0.625	15.9	23.52	598	20.75	527	10.01	254	2,350	10.5	1,018	1.4	1,103	4.9	5,000	34.5	22 to 28	29.8 to 38.0	
DW2	100	22	559	1.0	25.4	23.25	591	20.00	508	10.88	276	4,631	20.6	1,938	2.6	3,035	13.5	5,000	34.5	22 to 28	29.8 to 38.0	
DW2	100	24	610	1.0	25.4	25.25	641	22.00	559	10.88	276	4,906	21.8	2,257	3.1	3,324	14.8	5,000	34.5	24 to 30	32.5 to 40.7	
DW2	100	24	610	1.5	38.1	25.58	650	21.00	533	13.60	345	6,447	28.7	2,846	3.9	4,877	21.7	5,000	34.5	24 to 30	32.5 to 40.7	
DW2	100	26	660	1.0	25.4	27.25	692	24.00	610	10.88	276	5,160	23.0	2,588	3.5	3,613	16.1	5,000	34.5	26 to 34	35.3 to 46.1	
DW2	100	26	660	1.5	38.1	27.58	701	23.00	584	13.60	345	6,927	30.8	3,344	4.5	5,311	23.6	5,000	34.5	26 to 34	35.3 to 46.1	
DW2	100	30	762	1.0	25.4	31.25	794	28.00	711	10.88	276	5,567	24.8	3,255	4.4	4,191	18.6	5,000	34.5	30 to 38	40.7 to 51.5	
DW2	100	30	762	1.5	38.1	31.58	802	27.00	686	13.60	345	7,843	34.9	4,436	6.0	6,178	27.5	5,000	34.5	30 to 38	40.7 to 51.5	
DW2	100	36	914	1.0	25.4	37.25	946	34.00	864	10.88	276	5,971	26.6	4,236	5.7	5,058	22.5	5,000	34.5	36 to 44	48.8 to 59.7	
DW2	100	36	914	1.5	38.1	37.58	955	33.00	838	13.60	345	9,137	40.6	6,305	8.5	7,479	33.3	5,000	34.5	36 to 44	48.8 to 59.7	

All specifications given are based on typical configurations and may be varied to meet customer requirements or as a result of ongoing product development.

Leopard

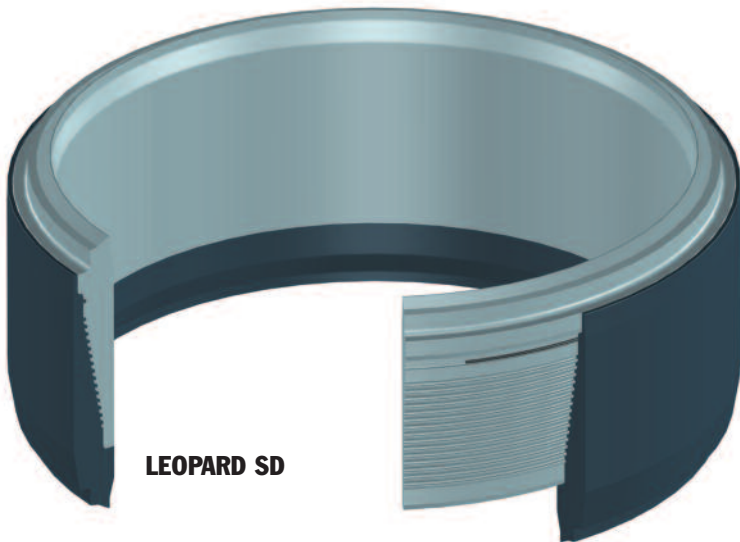

Threaded connector for conductor and casing

- Low torque make-up with rig tongs
Less than one turn make-up
- Integral 4 point anti-rotation provision
- Suitable for piling
- Reversible and reusable
- Visual indication of make-up
- Preloaded for fatigue

The Leopard combines the advantages of a preloaded, thread-type connector with the rapid make-up desired for offshore operations. It has strength characteristics equivalent to those of the conductor.

The Leopard has a high cone angle and is available in a twin or four start thread. When stabbed, the box swallows approximately 90% of the pin length. The stabbing guide prevents cross-threading. Full make-up is achieved in less than half a turn with a four start thread and less than one turn for a two start thread. The required make-up torque is 45,000 ft-lb for a 30" connection.

To prevent back-off during driving and to permit the connection to transmit torque, integral anti-rotation tabs can be engaged using a hand-held Hilti gun or manual shear tool. Use of the anti-rotation tabs increases breakout torque to as high as 90,000 ft-lb, depending on the number of tabs engaged.

Materials

Leopard connectors are typically made from 60ksi material for normal operations and 80ksi for driving applications. Alternate material options are available on request.

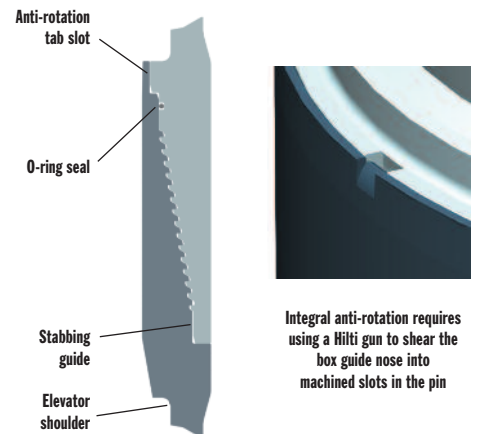

Type	Mat Yield (ksi)	Pipe Nominal OD		Pipe Wall Thickness		Connector OD		Connector ID		Made-up Length		Tension Yield		Bending Yield		Compression Yield		Internal Yield Pressure		Make-up Torque	
		(in)	(mm)	(in)	(mm)	(in)	(mm)	(in)	(mm)	(in)	(mm)	(kips)	(MN)	(kips ft)	(MNm)	(kips)	(MN)	(psi)	(MPa)	(kips ft)	(kNm)
S	60	18.625	473	0.435	11.0	19.91	506	17.76	451	8.00	203	1,268	5.6	469	0.6	1,064	4.7	2,500	17.2	18 to 24	24.4 to 32.5
SD	80	18.625	473	0.435	11.0	19.91	506	17.76	451	8.00	203	1,685	7.5	624	0.8	1,417	6.3	3,300	22.8	18 to 24	24.4 to 32.5
S	60	18.625	473	0.5	12.7	19.91	506	17.63	448	8.00	203	1,478	6.6	543	0.7	1,310	5.8	2,800	19.3	18 to 24	24.4 to 32.5
SD	80	18.625	473	0.5	12.7	19.91	506	17.63	448	8.00	203	1,964	8.7	722	1.0	1,737	7.7	3,500	24.1	18 to 24	24.4 to 32.5
S	60	20	508	0.438	11.1	21.19	538	18.50	470	8.75	222	1,801	8.0	718	1.0	1,666	7.4	2,300	15.9	20 to 26	27.1 to 35.3
SD	80	20	508	0.438	11.1	21.19	538	18.50	470	8.75	222	2,396	10.7	955	1.3	2,222	9.9	2,300	15.9	20 to 26	27.1 to 35.3
S	60	20	508	0.5	12.7	21.19	538	18.50	470	8.75	222	1,945	8.7	771	1.0	1,666	7.4	2,700	18.6	20 to 26	27.1 to 35.3
SD	80	20	508	0.5	12.7	21.19	538	18.50	470	8.75	222	2,594	11.5	1,028	1.4	2,222	9.9	2,700	18.6	20 to 26	27.1 to 35.3
S	60	20	508	0.625	15.9	21.19	538	18.50	470	8.75	222	2,130	9.5	834	1.1	1,666	7.4	3,300	22.8	20 to 26	27.1 to 35.3
SD	80	20	508	0.625	15.9	21.19	538	18.50	470	8.75	222	2,842	12.6	1,112	1.5	2,222	9.9	3,500	24.1	20 to 26	27.1 to 35.3
S	60	20	508	1.0	25.4	21.19	538	18.00	457	8.75	222	3,104	13.8	1,170	1.6	3,089	13.7	2,625	18.1	20 to 26	27.1 to 35.3
SD	80	20	508	1.0	25.4	21.19	538	18.00	457	8.75	222	4,119	18.3	1,553	2.1	4,119	18.3	3,500	24.1	20 to 26	27.1 to 35.3
S	60	24	610	1.0	25.4	25.77	655	21.50	546	13.12	333	3,757	16.7	1,729	2.3	3,078	13.7	3,000	20.7	24 to 30	32.5 to 40.7
SD	80	24	610	1.0	25.4	25.77	655	21.50	546	13.12	333	4,986	22.2	2,294	3.1	4,104	18.3	3,500	24.1	24 to 30	32.5 to 40.7
S	60	26	660	0.75	19.1	28.29	718	24.25	616	10.25	260	3,403	15.1	1,740	2.4	2,636	11.7	3,100	21.4	27 to 39	36.6 to 52.9
SD	80	26	660	0.75	19.1	28.29	718	24.25	616	10.25	260	4,539	20.2	2,321	3.1	3,510	15.6	3,500	24.1	28 to 39	38.0 to 52.9
S	60	26	660	1.0	25.4	28.29	718	24.00	610	13.01	330	4,084	18.2	1,740	2.4	3,346	14.9	3,500	24.1	29 to 39	39.3 to 52.9
SD	80	26	660	1.0	25.4	28.29	718	24.00	610	13.62	346	5,419	24.1	2,321	3.1	4,461	19.8	3,500	24.1	30 to 39	40.7 to 52.9
S	60	30	762	1.0	25.4	31.79	807	27.50	699	13.12	333	4,738	21.1	2,770	3.8	3,881	17.3	3,000	20.7	35 to 45	47.5 to 61.0
SD	80	30	762	1.0	25.4	31.79	807	27.50	699	13.12	333	6,317	28.1	3,694	5.0	5,175	23.0	3,500	24.1	35 to 45	47.5 to 61.0
S	60	30	762	1.5	38.1	31.79	807	27.00	686	13.12	333	6,950	30.9	3,931	5.3	6,950	30.9	3,500	24.1	35 to 45	47.5 to 61.0
SD	80	30	762	1.5	38.1	31.79	807	27.00	686	13.12	333	9,267	41.2	5,242	7.1	9,267	41.2	3,500	24.1	35 to 45	47.5 to 61.0
S	60	36	914	1.0	25.4	37.79	960	33.50	851	13.12	333	5,718	25.4	4,057	5.5	4,684	20.8	3,000	20.7	42 to 54	56.9 to 73.2
SD	80	36	914	1.0	25.4	37.79	960	33.50	851	13.12	333	7,624	33.9	5,409	7.3	6,245	27.8	3,500	24.1	42 to 54	56.9 to 73.2
S	60	36	914	1.5	38.1	37.79	960	33.00	838	13.12	333	8,413	37.4	5,806	7.9	8,413	37.4	3,500	24.1	42 to 54	56.9 to 73.2
SD	80	36	914	1.5	38.1	37.79	960	33.00	838	13.12	333	11,218	49.9	7,741	10.5	11,218	49.9	3,500	24.1	42 to 54	56.9 to 73.2
SEF	60	20	508	1.0	25.4	20.00	508	16.80	427	10.00	254	3,092	13.8	1,166	1.6	2,591	11.5	3,500	24.1	20 to 26	27.1 to 35.3
SDEF	80	20	508	1.0	25.4	20.00	508	16.80	427	10.00	254	4,119	18.3	1,553	2.1	3,456	15.4	3,500	24.1	20 to 26	27.1 to 35.3
SEF	60	30	762	1.0	25.4	30.00	762	25.20	640	15.00	381	4,154	18.5	2,429	3.3	3,854	17.1	3,500	24.1	35 to 45	47.5 to 61.0
SDEF	80	30	762	1.0	25.4	30.00	762	25.20	640	15.00	381	5,466	24.3	3,196	4.3	5,102	22.7	3,500	24.1	35 to 45	47.5 to 61.0
SEF	60	30	762	1.5	38.1	30.00	762	25.20	640	15.00	381	6,957	30.9	3,935	5.3	5,829	25.9	3,500	24.1	35 to 45	47.5 to 61.0
SDEF	80	30	762	1.5	38.1	30.00	762	25.20	640	15.00	381	9,267	41.2	5,242	7.1	7,776	34.6	3,500	24.1	35 to 45	47.5 to 61.0
SEF	60	36	914	1.0	25.4	36.00	914	31.75	806	14.69	373	4,948	22.0	3,511	4.8	4,519	20.1	3,000	20.7	42 to 54	56.9 to 73.2
SDEF	80	36	914	1.0	25.4	36.00	914	31.75	806	14.69	373	6,947	29.3	4,681	6.3	6,037	26.9	3,500	24.1	42 to 54	56.9 to 73.2
SEF	60	36	914	1.5	38.1	36.00	914	31.20	792	16.19	411	8,617	38.3	5,946	8.1	7,137	31.7	3,500	24.1	42 to 54	56.9 to 73.2
SDEF	80	36	914	1.5	38.1	36.00	914	31.20	792	16.19	411	11,380	50.6	7,854	10.6	9,690	43.1	3,500	24.1	42 to 54	56.9 to 73.2

All specifications given are based on typical configurations and may be varied to meet customer requirements or as a result of ongoing product development.

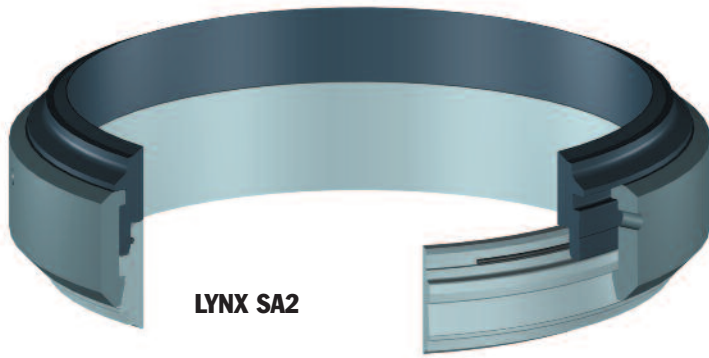

Weight-set connector for conductor

- Assembly requires no special tools or personnel
- Suitable for piling
- Visual indication of make-up
- Anti-rotation resistant
- Quick release
- Remote release

The Lynx is a robust connector for conductors. It is the simplest type of connector to run, requiring no special tools or personnel. The connector is designed to meet the bending capabilities of the mating pipe body and be piled.

All Lynx models stab easily, self align axially and assemble under the weight of the joint. When the box is stabbed over the pin, joint weight expands the lock-ring, the abutment faces meet and the lock-ring snaps closed. Full make-up is visually confirmed by inspection of the lock-ring. Lynx connectors disengage by running jacking bolts through the lock-ring to release the pin.

Materials

Lynx connectors are typically made from HIHOS, an Oil States developed, high strength, micro-alloy steel (100,000 psi yield). Alternate material options are available on request.

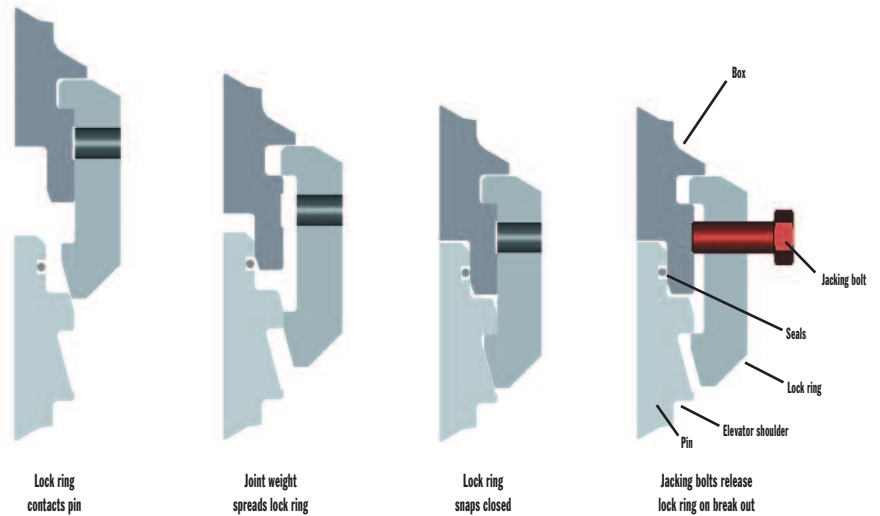

Type	Mat Yield	Pipe Nominal OD		Pipe Wall Thickness		Connector OD		Connector ID		Made-up Length		Tension Yield		Bending Yield		Compression Yield		Internal Yield Pressure		Torsion	
	(ksi)	(in)	(mm)	(in)	(mm)	(in)	(mm)	(in)	(mm)	(in)	(mm)	(kips)	(MN)	(kips ft)	(MNm)	(kips)	(MN)	(psi)	(MPa)	(kips ft)	(KNm)
SA2	100	18.625	473	0.435	11.0	21.24	540	17.76	451	5.75	146	1,350	6.0	516	0.7	1,688	7.5	3,000	20.7	13.0	17.6
SA2	100	20	508	0.625	15.9	22.33	567	18.75	476	6.04	154	1,527	6.8	819	1.1	2,092	9.3	3,000	20.7	15.0	20.3
SA2	100	22	559	0.625	15.9	24.33	618	20.75	527	6.04	154	1,685	7.5	1,000	1.4	2,308	10.3	3,000	20.7	15.5	21.0
SA2	100	24	610	0.75	19.1	27.50	699	22.00	559	9.07	230	2,555	11.4	1,729	2.3	3,757	16.7	3,000	20.7	39.0	52.9
SA2	100	24	610	1.0	25.4	27.50	699	22.00	559	9.07	230	2,555	11.4	1,729	2.3	3,757	16.7	3,000	20.7	39.0	52.9
SA2	100	26	660	0.75	19.1	29.50	749	24.00	610	9.07	230	2,777	12.4	2,049	2.8	4,084	18.2	3,000	20.7	42.0	56.9
SA2	100	26	660	1.0	25.4	29.50	749	24.00	610	9.07	230	2,777	12.4	2,049	2.8	4,084	18.2	3,000	20.7	42.0	56.9
SA2	100	30	762	0.75	19.1	33.50	851	28.00	711	9.07	230	3,222	14.3	2,770	3.8	4,738	21.1	3,000	20.7	50.0	67.8
SA2	100	30	762	1.0	25.4	33.50	851	28.00	711	9.07	230	3,222	14.3	2,770	3.8	4,738	21.1	3,000	10.3	50.0	67.8
SA2	100	36	914	1.0	25.4	39.50	1003	34.00	864	9.07	230	3,888	17.3	4,057	5.5	5,718	25.4	3,000	20.7	60.0	81.3

HD (IF)	100	20	508	1.0	25.4	22.71	577	18.00	457	10.34	263	3,104	13.8	1,170	1.6	3,104	13.8	3,000	20.7	15.0	20.3
HD (IF)	100	22	559	1.0	25.4	24.71	628	20.00	508	10.34	263	3,431	15.3	1,436	1.9	3,431	15.3	3,000	20.7	15.5	21.0
HD	100	30	762	1.0	25.4	34.10	866	27.00	686	15.38	391	6,984	31.1	3,950	5.4	6,984	31.1	3,000	10.3	50.0	67.8
HD (IF)	100	30	762	1.5	38.1	34.10	866	27.00	686	15.38	391	6,984	31.1	3,950	5.4	6,984	31.1	3,000	20.7	50.0	67.8
HD (IF)	100	36	914	1.0	25.4	41.00	1041	34.00	864	15.38	391	8,454	37.6	5,834	7.9	8,454	37.6	3,000	20.7	60.0	81.3
HD (IF)	100	36	914	1.5	38.1	40.00	1016	33.00	838	15.38	391	8,454	37.6	5,834	7.9	8,454	37.6	3,000	20.7	60.0	81.3

HDHT (IF)	100	20	508	1.0	25.4	22.71	577	18.00	457	10.17	258	3,104	13.8	1,170	1.6	3,104	13.8	3,000	20.7	500	677.9
HDHT (EF)	100	30	762	1.5	38.1	30.00	762	23.00	584	18.16	461	5,098	22.7	3,753	5.1	6,111	27.2	3,000	20.7	1,419	1923.9
HDHT	100	30	762	1.0	25.4	34.10	866	27.00	686	15.26	388	6,984	31.1	3,950	5.4	6,984	31.1	3,000	10.3	1,650	2,237
HDHT (IF)	100	30	762	1.5	38.1	34.10	866	27.00	686	15.26	388	6,984	31.1	3,950	5.4	6,984	31.1	3,000	20.7	1,650	2,237
HDHT (EF)	100	36	914	1.5	38.1	36.00	914	29.00	737	18.16	461	6,002	26.7	5,251	7.1	7,101	31.6	3,000	20.7	1,760	2386.2
HDHT	100	36	914	1.0	25.4	40.00	1016	33.00	838	15.26	388	8,454	37.6	5,834	7.9	8,454	37.6	3,000	10.3	2,000	2,712
HDHT (IF)	100	36	914	1.5	38.1	40.00	1016	33.00	838	15.26	388	8,454	37.6	5,834	7.9	8,454	37.6	3,000	20.7	2,000	2,712
HDHT (IF)	100	36	914	2.0	50.8	40.00	1016	32.00	813	15.26	388	8,454	37.6	5,834	7.9	11,109	49.4	3,000	20.7	3,000	4,067

All specifications given are based on typical configurations and may be varied to meet customer requirements or as a result of ongoing product development.

Lynx

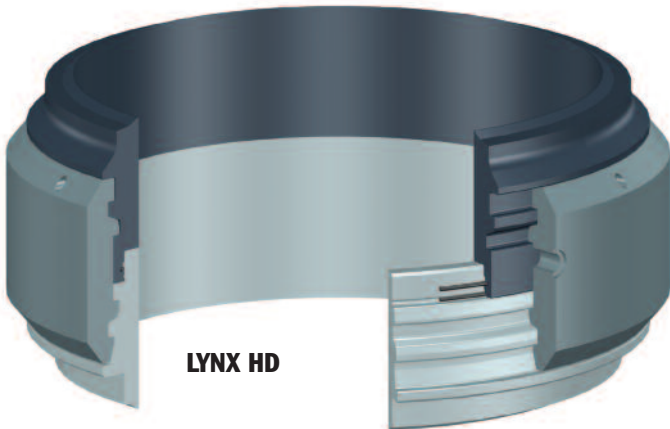

Lynx HD is a heavy duty model suited to 1.5" Wall pipe, this utilises a twin load shoulder to increase capacity.

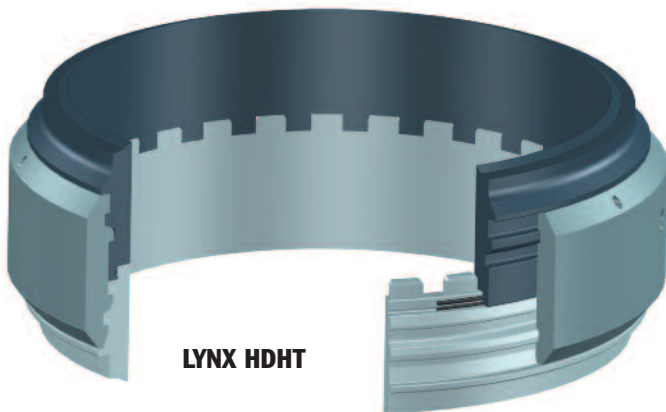

Lynx HDHT is an extremely High Torque Resistant version of the connector for trawler resistant applications

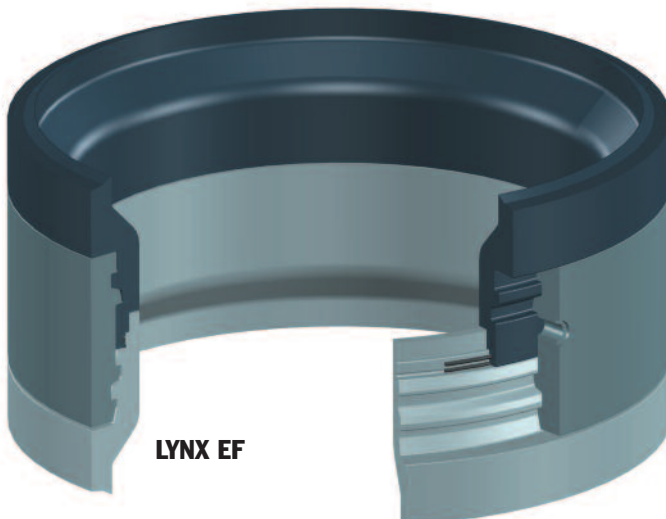

Lynx HDEF is an external flush version of the connector for use in Jetting applications

Lynx versions

- SA2 Standard Duty
- HD Heavy Duty
- HT High Torque
- EF External Flush
- Hydraulic Remote Release

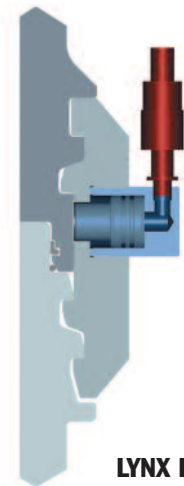

Lynx is also available with a hydraulic remote release option for mud line release applications.

Puma

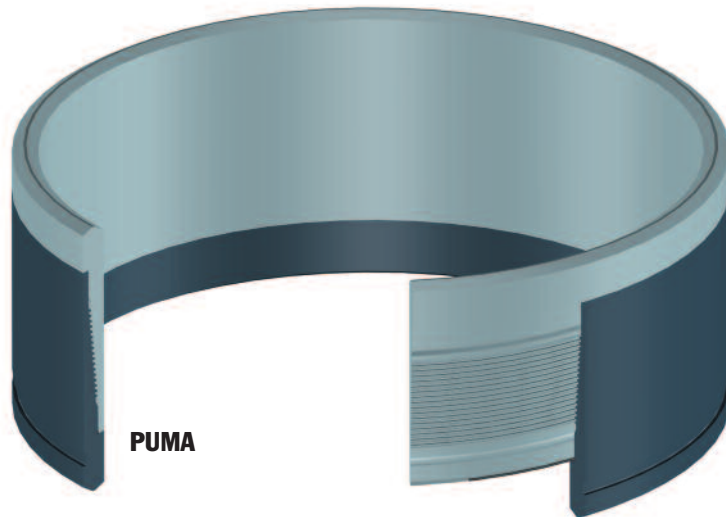

Flush connector for conductor and pile

- Flush OD flush ID
- Suitable for piling
- Visual indication of make-up
- Elastomer o-ring seals
- Low torque, fast make-up
- Pre-loaded

The Puma is a flush-threaded connector for use on exploration and platform drilling operations where size restrictions preclude the use of conventional upset connectors.

The connector is fully driveable and utilises high yield connector material to enable the connection to exceed pipe body capacities, whilst using standard pipe grades.

The connection can be installed using conventional casing tongs without any additional requirement for compensated weight release.

Materials

Puma connectors are typically made from HIHOS, an Oil States developed, high-strength, micro-alloy steel (100,000 psi yield). Alternate material options are available on request.

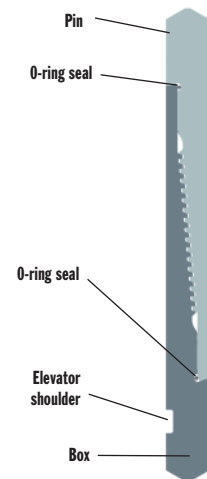

Type	Mat Yield	Pipe Nominal OD		Pipe Wall Thickness		Connector OD		Connector ID		Made-up Length		Tension Yield		Bending Yield		Compression Yield		Internal Yield Pressure		Make-up Torque	
	(ksi)	(in)	(mm)	(in)	(mm)	(in)	(mm)	(in)	(mm)	(in)	(mm)	(kips)	(MN)	(kips ft)	(MNm)	(kips)	(MN)	(psi)	(MPa)	(kips ft)	(kNm)
F	60	18.625	473	0.435	11.0	18.63	473	17.76	451	7.88	200	736	3.3	273	0.4	895	4.0	3,000	20.7	18 to 21	24.4 to 28.5
DF	100	18.625	473	0.435	11.0	18.63	473	17.76	451	7.88	200	1,227	5.5	454	0.6	1,491	6.6	3,000	20.7	18 to 21	24.4 to 28.5
F	60	20	508	0.5	12.7	20.00	508	19.00	483	7.15	182	935	4.2	371	0.5	1,103	4.9	3,000	20.7	20 to 23	27.1 to 31.2
DF	100	20	508	0.5	12.7	20.00	508	19.00	483	7.15	182	1,559	6.9	618	0.8	1,838	8.2	3,000	20.7	20 to 23	27.1 to 31.2
F	60	20	508	0.625	15.9	20.00	508	18.75	476	7.15	182	1,262	5.6	494	0.7	1,370	6.1	3,000	20.7	20 to 23	27.1 to 31.2
DF	100	20	508	0.625	15.9	20.00	508	18.75	476	7.15	182	2,104	9.4	823	1.1	2,283	10.2	3,000	20.7	20 to 23	27.1 to 31.2
F	60	20	508	0.75	19.1	20.00	508	18.50	470	8.57	218	1,585	7.0	613	0.8	1,633	7.3	3,000	20.7	20 to 23	27.1 to 31.2
DF	100	20	508	0.75	19.1	20.00	508	18.50	470	8.57	218	2,641	11.7	1,021	1.4	2,721	12.1	3,000	20.7	20 to 23	27.1 to 31.2
F	60	20	508	1.0	25.4	20.00	508	18.00	457	11.05	281	2,217	9.9	836	1.1	2,149	9.6	3,000	20.7	20 to 23	27.1 to 31.2
DF	100	20	508	1.0	25.4	20.00	508	18.00	457	11.05	281	3,695	16.4	1,393	1.9	3,581	15.9	3,000	20.7	20 to 23	27.1 to 31.2
F	60	22	559	0.625	15.9	22.00	559	20.75	527	7.02	178	1,348	6.0	584	0.8	1,511	6.7	3,000	20.7	22 to 25	29.8 to 33.9
DF	100	22	559	0.625	15.9	22.00	559	20.75	527	7.02	178	2,247	10.0	973	1.3	2,518	11.2	3,000	20.7	22 to 25	29.8 to 33.9
F	60	22	559	0.75	19.1	22.00	559	20.50	521	8.42	214	1,705	7.6	730	1.0	1,802	8.0	3,000	20.7	22 to 25	29.8 to 33.9
DF	100	22	559	0.75	19.1	22.00	559	20.50	521	8.42	214	2,842	12.6	1,217	1.6	3,004	13.4	3,000	20.7	22 to 25	29.8 to 33.9
F	60	22	559	1.0	25.4	22.00	559	20.00	508	11.05	281	2,407	10.7	1,007	1.4	2,375	10.6	3,000	20.7	22 to 25	29.8 to 33.9
DF	100	22	559	1.0	25.4	22.00	559	20.00	508	11.05	281	4,011	17.8	1,679	2.3	3,958	17.6	3,000	20.7	22 to 25	29.8 to 33.9
F	60	24	610	1.0	25.4	24.00	610	22.00	559	11.05	281	2,588	11.5	1,191	1.6	2,601	11.6	3,000	20.7	24 to 28	32.5 to 38.0
DF	100	24	610	1.0	25.4	24.00	610	22.00	559	11.05	281	4,314	19.2	1,985	2.7	4,335	19.3	3,000	20.7	24 to 28	32.5 to 38.0
F	60	26	660	0.75	19.1	26.00	660	24.50	622	12.05	306	1,922	8.5	983	1.3	2,142	9.5	3,000	20.7	26 to 30	35.3 to 40.7
DF	100	26	660	0.75	19.1	26.00	660	24.50	622	12.05	306	3,203	14.2	1,638	2.2	3,570	15.9	3,000	20.7	26 to 30	35.3 to 40.7
F	60	26	660	1.0	25.4	26.00	660	24.00	610	12.05	306	2,761	12.3	1,385	1.9	2,827	12.6	3,000	20.7	26 to 30	35.3 to 40.7
DF	100	26	660	1.0	25.4	26.00	660	24.00	610	12.05	306	4,602	20.5	2,309	3.1	4,712	21.0	3,000	20.7	26 to 30	35.3 to 40.7
F	60	30	762	1.0	25.4	30.00	762	28.00	711	11.05	281	3,083	13.7	1,803	2.4	3,280	14.6	3,000	20.7	30 to 35	40.7 to 47.5
DF	100	30	762	1.0	25.4	30.00	762	28.00	711	11.05	281	5,138	22.9	3,005	4.1	5,466	24.3	3,000	20.7	30 to 35	40.7 to 47.5
F	60	30	762	1.5	38.1	30.00	762	27.00	686	16.54	420	4,988	22.2	2,821	3.8	4,835	21.5	3,000	20.7	30 to 35	40.7 to 47.5
DF	100	30	762	1.5	38.1	30.00	762	27.00	686	16.54	420	8,313	37.0	4,702	6.4	8,058	35.8	3,000	20.7	30 to 35	40.7 to 47.5
F	60	36	914	1.0	25.4	36.00	914	34.00	864	11.05	281	3,503	15.6	2,485	3.4	3,958	17.6	3,000	20.7	36 to 42	48.8 to 56.9
DF	100	36	914	1.0	25.4	36.00	914	34.00	864	11.05	281	5,839	26.0	4,142	5.6	6,597	29.3	3,000	20.7	36 to 42	48.8 to 56.9
F	60	36	914	1.25	31.8	36.00	914	33.50	851	14.04	357	4,672	20.8	3,269	4.4	4,913	21.9	3,000	20.7	36 to 42	48.8 to 56.9
DF	100	36	914	1.25	31.8	36.00	914	33.50	851	14.04	357	7,787	34.6	5,448	7.4	8,188	36.4	3,000	20.7	36 to 42	48.8 to 56.9
F	60	36	914	1.5	38.1	36.00	914	33.00	838	16.85	428	5,824	25.9	4,019	5.4	5,853	26.0	3,000	20.7	36 to 42	48.8 to 56.9
DF	100	36	914	1.5	38.1	36.00	914	33.00	838	16.85	428	9,706	43.2	6,698	9.1	9,755	43.4	3,000	20.7	36 to 42	48.8 to 56.9
F	60	36	914	2.0	50.8	36.00	914	32.00	813	16.85	428	8,075	35.9	5,421	7.3	7,691	34.2	3,000	20.7	36 to 42	48.8 to 56.9
DF	100	36	914	2.0	50.8	36.00	914	32.00	813	16.85	428	13,459	59.9	9,035	12.2	12,818	57.0	3,000	20.7	36 to 42	48.8 to 56.9
F	60	42	1067	1.0	25.4	42.00	1067	40.00	1016	14.04	357	3,849	17.1	3,211	4.4	4,637	20.6	3,000	20.7	42 to 48	56.9 to 65.1
DF	100	42	1067	1.0	25.4	42.00	1067	40.00	1016	14.04	357	6,415	28.5	5,352	7.3	7,728	34.4	3,000	20.7	42 to 48	56.9 to 65.1
F	60	42	1067	1.25	31.8	42.00	1067	39.50	1003	14.04	357	5,225	23.2	4,308	5.8	5,761	25.6	3,000	20.7	42 to 48	56.9 to 65.1
DF	100	42	1067	1.25	31.8	42.00	1067	39.50	1003	14.04	357	8,709	38.7	7,180	9.7	9,601	42.7	3,000	20.7	42 to 48	56.9 to 65.1

All specifications given are based on typical configurations and may be varied to meet customer requirements or as a result of ongoing product development.

Merlin

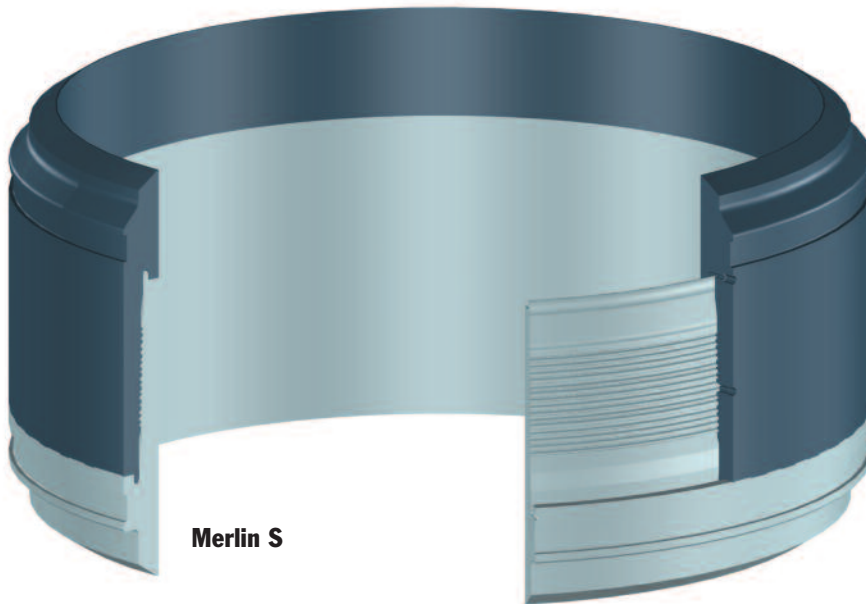

Versatile, high strength high fatigue connector for conductor, structural tubular and pipelines

- Unique, non-rotational assembly
- Compact, slimline design
- Metal-to-metal seals
- Internal and external abutment
- Suitable for piling
- Reversible and reusable
- Ultra-high fatigue life and static strength

Merlin connectors combine superior static strength and fatigue life with fast, non-rotational make-up and an extremely slim profile; a Merlin connector typically has a cross-sectional wall thickness of only 1.5 inches. These connectors have been used in sizes up to 60 inches OD and for applications including open-hole and tieback casing, conductors, structural tubulars, pipeline risers and TLP Tendons. The Merlin S is the slim line version, the Merlin D and HD are drivable models and the Merlin R is for use with riser applications. The Merlin Tension Leg Element (TLE) is also available for extreme axial fatigue conditions.

The Merlin connection has a unique non-helical thread design, which incorporates Oil States patented tooth crest relief profile. The connector geometry has been designed to ensure that the teeth can only interlock in the fully made-up position. The connection is assembled in approximately 5 minutes using an OSI supplied hydraulic clamp and air-operated power pack. After stabbing, the clamp is fitted around the connector, and hydraulic pressure is injected between the pin and box. As the pressure expands the box contracts the pin, the clamp pulls the two components together. When pressure is released, the box “shrinks” onto the pin. The wedging action of the teeth converts radial preload into an extremely high axial preload that maintains connector stiffness and enhances tension fatigue characteristics. The level of preload generated in Merlin is not possible to achieve with an equivalent sized conventional helical threaded connector. Make-up is visually confirmed by inspecting the external abutment faces. Break-out is achieved by reversing the process. Merlin connectors are re-usable, with only visual inspection required.

The connector incorporates internal and external abutment faces, which ensure pile fatigue is minimised through the teeth, this enables the connector to have high-in place fatigue performance even after piling.

Materials

Merlin connectors are typically made from HIHOS, an Oil States developed, high-strength, micro-alloy steel (100,000 psi yield). Alternate material options are available on request.

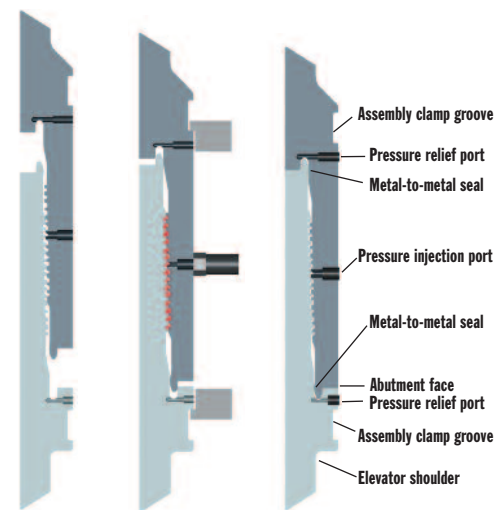

Stabbed
Box swallows
approximately
90% of
pin length

Assembly
Hydraulic pressure
expands box;
clamp draws
components together

Made up
Connection
is pre-loaded
both radially
and axially



Merlin

Merlin Selection

S Standard
1" Standard Duty X52
16 Tooth Design

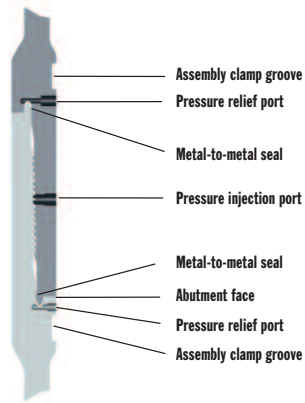
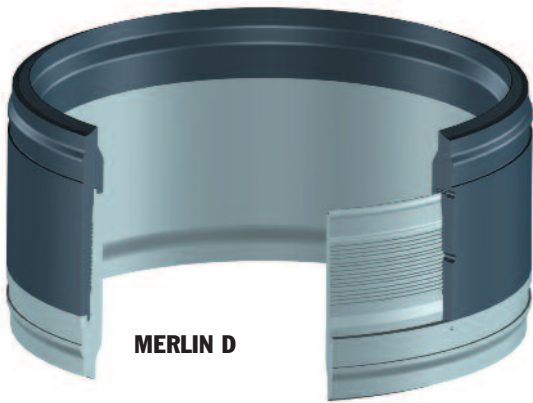

D Driveable
1" Driveable X52/X56
16 Tooth Design

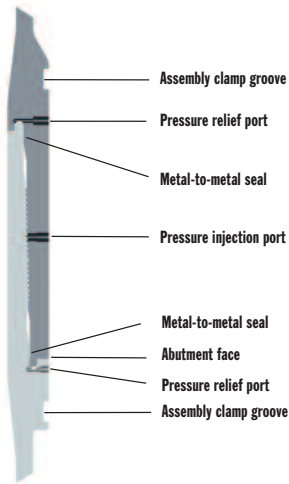

HD Heavy Duty
1.5" Driveable X52/X56
24 Tooth Design

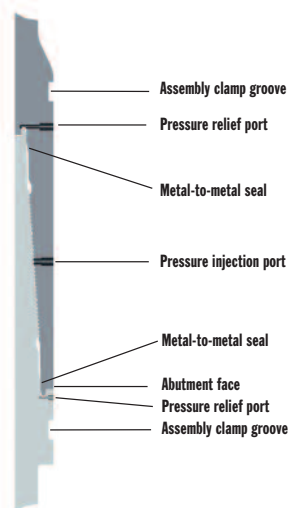

R High Pressure Riser
1.5" High Pressure X80
36 Tooth Design

Type	Mat Yield		Pipe Nominal OD		Pipe Wall Thickness		Connector OD		Connector ID		Made-up Length		Tension Yield		Bending Yield		Compression Yield		Internal Yield Pressure	
	(ksi)	(in)	(mm)	(in)	(mm)	(in)	(mm)	(in)	(mm)	(in)	(mm)	(in)	(mm)	(kips)	(MN)	(kips ft)	(MNm)	(kips)	(MN)	(psi)
SEF	100	20	508	0.625	15.9	20.00	508	17.00	432	15.10	384	3,223	14.3	1,215	1.6	3,581	15.9	5,000	34.5	
SIF	100	20	508	0.625	15.9	21.75	552	18.75	476	15.10	384	3,343	14.9	1,260	1.7	3,581	15.9	5,000	34.5	
SEF	100	20	508	1.0	25.4	20.00	508	17.00	432	15.10	384	3,223	14.3	1,215	1.6	3,581	15.9	5,000	34.5	
SIF	100	20	508	1.0	25.4	21.00	533	18.00	457	15.10	384	3,343	14.9	1,260	1.7	3,581	15.9	5,000	34.5	
SEF	100	22	559	0.625	15.9	22.00	559	19.00	483	15.10	384	3,695	16.4	1,546	2.1	3,958	17.6	5,000	34.5	
SIF	100	22	559	0.625	15.9	23.75	603	20.75	527	15.10	384	3,695	16.4	1,546	2.1	3,958	17.6	5,000	34.5	
SEF	100	22	559	1.0	25.4	22.00	559	19.00	483	15.10	384	3,695	16.4	1,546	2.1	3,958	17.6	5,000	34.5	
SIF	100	22	559	1.0	25.4	23.00	584	20.00	508	15.10	384	3,695	16.4	1,546	2.1	3,958	17.6	5,000	34.5	
SEF	100	24	610	1.0	25.4	24.00	610	21.00	533	15.10	384	4,046	18.0	1,862	2.5	4,335	19.3	5,000	34.5	
SIF	100	24	610	1.0	25.4	25.00	635	22.00	559	15.10	384	4,046	18.0	1,862	2.5	4,335	19.3	5,000	34.5	
SEF	100	24	610	1.5	38.1	24.00	610	21.00	533	15.10	384	4,046	18.0	1,862	2.5	4,335	19.3	5,000	34.5	
SIF	100	24	610	1.5	38.1	24.00	610	21.00	533	15.10	384	4,046	18.0	1,862	2.5	4,335	19.3	5,000	34.5	
SEF	100	26	660	0.75	19.1	26.00	660	23.00	584	15.10	384	4,398	19.6	2,206	3.0	4,712	21.0	5,000	34.5	
SIF	100	26	660	0.75	19.1	27.50	699	24.50	622	15.10	384	4,398	19.6	2,206	3.0	4,712	21.0	5,000	34.5	
SEF	100	26	660	1.0	25.4	26.00	660	23.00	584	15.10	384	4,398	19.6	2,206	3.0	4,712	21.0	5,000	34.5	
SIF	100	26	660	1.0	25.4	27.00	686	24.00	610	15.10	384	4,398	19.6	2,206	3.0	4,712	21.0	5,000	34.5	
SEF	100	26	660	1.25	31.8	26.00	660	23.00	584	15.10	384	4,398	19.6	2,206	3.0	4,712	21.0	5,000	34.5	
SIF	100	26	660	1.25	31.8	26.50	673	23.50	597	15.10	384	4,398	19.6	2,206	3.0	4,712	21.0	5,000	34.5	
SEF	100	26	660	1.5	38.1	26.00	660	23.00	584	15.10	384	4,398	19.6	2,206	3.0	4,712	21.0	5,000	34.5	
SIF	100	26	660	1.5	38.1	26.00	660	23.00	584	15.10	384	4,398	19.6	2,206	3.0	4,712	21.0	5,000	34.5	
SEF	100	30	762	1.0	25.4	30.00	762	27.00	686	15.10	384	5,102	22.7	2,983	4.0	5,466	24.3	5,000	34.5	
SIF	100	30	762	1.0	25.4	31.00	787	28.00	711	15.10	384	5,102	22.7	2,983	4.0	5,466	24.3	5,000	34.5	
SEF	100	36	914	1.0	25.4	36.00	914	33.00	838	15.10	384	5,718	25.4	4,057	5.5	6,597	29.3	4,850	33.4	
SIF	100	36	914	1.0	25.4	37.00	940	34.00	864	15.10	384	5,718	25.4	4,057	5.5	6,597	29.3	4,850	33.4	
DEF	100	20	508	0.625	15.9	20.00	508	16.50	419	15.10	384	3,223	14.3	1,215	1.6	4,775.2	21.2	5,000	34.5	
DIF	100	20	508	0.625	15.9	22.25	565	18.75	476	15.10	384	3,343	14.9	1,260	1.7	4,775.2	21.2	5,000	34.5	
DEF	100	20	508	0.75	19.1	20.00	508	16.50	419	15.10	384	3,223	14.3	1,215	1.6	4,775.2	21.2	5,000	34.5	
DIF	100	20	508	0.75	19.1	22.00	559	18.50	470	15.10	384	3,343	14.9	1,260	1.7	4,775.2	21.2	5,000	34.5	
DEF	100	20	508	1.0	25.4	20.00	508	16.50	419	15.10	384	3,223	14.3	1,215	1.6	4,775.2	21.2	5,000	34.5	
DIF	100	20	508	1.0	25.4	21.50	546	18.00	457	15.10	384	3,343	14.9	1,260	1.7	4,775.2	21.2	5,000	34.5	
DEF	100	22	559	0.625	15.9	22.00	559	18.50	470	15.10	384	3,695	16.4	1,546	2.1	5,277.9	23.5	5,000	34.5	
DIF	100	22	559	0.625	15.9	24.25	616	20.75	527	15.10	384	3,695	16.4	1,546	2.1	5,277.9	23.5	5,000	34.5	
DEF	100	22	559	1.0	25.4	22.00	559	18.50	470	15.10	384	3,695	16.4	1,546	2.1	5,277.9	23.5	5,000	34.5	
DIF	100	22	559	1.0	25.4	23.50	597	20.00	508	15.10	384	3,695	16.4	1,546	2.1	5,277.9	23.5	5,000	34.5	
DEF	100	22	559	1.25	31.8	22.00	559	18.50	470	15.10	384	3,695	16.4	1,546	2.1	5,277.9	23.5	5,000	34.5	
DIF	100	22	559	1.25	31.8	23.00	584	19.50	495	15.10	384	3,695	16.4	1,546	2.1	5,277.9	23.5	5,000	34.5	
DEF	100	24	610	1.0	25.4	24.00	610	20.50	521	15.10	384	4,046	18.0	1,862	2.5	5,780.5	25.7	5,000	34.5	
DIF	100	24	610	1.0	25.4	25.50	648	22.00	559	15.10	384	4,046	18.0	1,862	2.5	5,780.5	25.7	5,000	34.5	
DEF	100	24	610	1.25	31.8	24.00	610	20.50	521	15.10	384	4,046	18.0	1,862	2.5	5,780.5	25.7	5,000	34.5	
DIF	100	24	610	1.25	31.8	25.00	635	21.50	546	15.10	384	4,046	18.0	1,862	2.5	5,780.5	25.7	5,000	34.5	
DEF	100	24	610	1.5	38.1	24.00	610	20.50	521	15.10	384	4,046	18.0	1,862	2.5	5,780.5	25.7	5,000	34.5	
DIF	100	24	610	1.5	38.1	24.50	622	21.00	533	15.10	384	4,046	18.0	1,862	2.5	5,780.5	25.7	5,000	34.5	
DEF	100	26	660	0.75	19.1	26.00	660	22.50	572	15.10	384	4,398	19.6	2,206	3.0	6,283.2	27.9	5,000	34.5	
DIF	100	26	660	0.75	19.1	28.00	711	24.50	622	15.10	384	4,398	19.6	2,206	3.0	6,283.2	27.9	5,000	34.5	
DEF	100	26	660	1.0	25.4	26.00	660	22.50	572	15.10	384	4,398	19.6	2,206	3.0	6,283.2	27.9	5,000	34.5	
DIF	100	26	660	1.0	25.4	27.50	699	24.00	610	15.10	384	4,398	19.6	2,206	3.0	6,283.2	27.9	5,000	34.5	
DEF	100	26	660	1.25	31.8	26.00	660	22.50	572	15.10	384	4,398	19.6	2,206	3.0	6,283.2	27.9	5,000	34.5	
DIF	100	26	660	1.25	31.8	27.00	686	23.50	597	15.10	384	4,398	19.6	2,206	3.0	6,283.2	27.9	5,000	34.5	
DEF	100	26	660	1.5	38.1	26.00	660	22.50	572	15.10	384	4,398	19.6	2,206	3.0	6,283.2	27.9	5,000	34.5	
DIF	100	26	660	1.5	38.1	26.50	673	23.00	584	15.10	384	4,398	19.6	2,206	3.0	6,283.2	27.9	5,000	34.5	
DEF	100	30	762	1.0	25.4	30.00	762	26.50	673	15.10	384	5,102	22.7	2,983	4.0	7,288.5	32.4	5,000	34.5	
DIF	100	30	762	1.0	25.4	31.50	800	28.00	711	15.10	384	5,102	22.7	2,983	4.0	7,288.5	32.4	5,000	34.5	
DEF	100	30	762	1.5	38.1	30.00	762	26.50	673	15.10	384	5,102	22.7	2,983	4.0	7,288.5	32.4	5,000	34.5	
DIF	100	30	762	1.5	38.1	30.50	775	27.00	686	15.10	384	5,102	22.7	2,983	4.0	7,288.5	32.4	5,000	34.5	
DEF	100	36	914	1.0	25.4	36.00	914	32.50	826	15.10	384	6,158	27.4	4,369	5.9	8,796.5	39.1	4,850	33.4	
DIF	100	36	914	1.0	25.4	37.50	953	34.00	864	15.10	384	6,158	27.4	4,369	5.9	8,796.5	39.1	4,850	33.4	
DEF	100	36	914	1.25	31.8	36.00	914	32.50	826	15.10	384	6,158	27.4	4,369	5.9	8,796.5	39.1	5,000	34.5	
DIF	100	36	914	1.25	31.8	37.00	940	33.50	851	15.10	384	6,158	27.4	4,369	5.9	8,796.5	39.1	5,000	34.5	
DEF	100	36	914	1.5	38.1	36.00	914	32.50	826	15.10	384	6,158	27.4	4,369	5.9	8,796.5	39.1	5,000	34.5	
DIF	100	36	914	1.5	38.1	36.50	927	33.00	838	15.10	384	6,158	27.4	4,369	5.9	8,796.5	39.1	5,000	34.5	
HDEF	100	20	508	0.625	15.9	20.00	508	16.83	427.48	18.50	470	3,880	17.3	1,463	2.0	4,775	21.2	6,000	41.4	
HDIF	100	20	508	0.625	15.9	21.92	557	18.75	476	18.50	470	3,880	17.3	1,463	2.0	4,775	21.2	6,000	41.4	
HDEF	100	20	508	1.0	25.4	20.00	508	16.83	427	18.50	470	3,880	17.3	1,463	2.0	4,775	21.2	6,000	41.4	
HDIF	100	20	508	1.0	25.4	21.17	538	18.00	457	18.50	470	3,880	17.3	1,463	2.0	4,775	21.2	6,000	41.4	
HDEF	100	22	559	0.625	15.9	22.00	559	18.83	478	18.50	470	4,288	19.1	1,795	2.4	5,278	23.5	6,000	41.4	
HDIF	100	22	559	0.625	15.9	23.92	607	20.75	527	18.50	470	4,288	19.1	1,795	2.4	5,278	23.5	6,000	41.4	
HDEF	100	22	559	1.																

OIL STATES INDUSTRIES
1155 DAIRY ASHFORD ST., SUITE 700
HOUSTON, TEXAS 77079
Tel: +1 713 510 2200
Fax: +1 713 510 2307
e-mail: sales@oilstates-us.com

OIL STATES INDUSTRIES (UK) LTD
BLACKNESS ROAD
ALTENS INDUSTRIAL ESTATE
ABERDEEN AB12 3LH
Tel: +44 (0) 1224 290000
Fax: +44 (0) 1224 290110
e-mail: sales@oilstates-uk.com
www.oilstates.com

OIL STATES INDUSTRIES (ASIA) PTE
42-H PENJURU ROAD
SINGAPORE 609158
Tel: +65 67737555
Fax: +65 67737667
e-mail: sales@osiasia.com.sg

